

#70

CHELSEA space

We are watching: OZ in London

Private view: Tuesday 13 June, 6-8.30pm

Exhibition continues: 14 June – 14 July 2017

Donald Smith
Director of Exhibitions

Chelsea College of Arts

16 John Islip Street
London
SW1P 4JU
United Kingdom
Tel: 020 7514 6983

Email:
info@chelseaspacespace.org

Website:
www.chelseaspacespace.org

'They [the conservative elite] were overly terrified, and that somehow in the fluorescent pages of our magazine in which we dealt with revolutionary politics, drugs, sexuality, racism, trying to be much more candid about these matters and very very defined, I think at last they felt if they could shut us up, if they could stop Oz, that they could somehow stop the rebellion.'

Richard Neville, 'The Oz Trial, Innocents Defiled?', BBC Radio 4, 17 May 1990

OZ magazine (London, 1967-1973), has come to be known as a publication that typified the Sixties, through its experimental approach to design, editorial and the lifestyle it depicted, often through its contributors whose lives became enmeshed in the publication as it gained popularity and notoriety.

The exhibition, **We Are Watching: OZ in London**, will explore the creative output of a range of the magazine's contributors over the six years that it was based in London, where it provided a voice to young journalists, artists and designers. This international network included Richard Neville, Martin Sharp, Felix Dennis, Jim Anderson, Robert Whitaker, Philippe Mora and Germaine Greer. Several other individuals were also fundamental in the success of OZ, their hard work uncredited at the time, including Marsha Rowe and Louise Ferrier.

As well as focusing on the obscenity trial against the editors that took place in 1971 at the Old Bailey, the exhibition highlights many of the social and political issues that were addressed within the magazine. Through satire, serious journalism, art and design, OZ was part of the underground press that formed a voice against the establishment, raising awareness, and often controversially so, of issues such as race and gender prejudice, mistreatment of prisoners, homosexuality, and drug awareness.

Curated by Cherie Silver, the exhibition includes material from: the Richard Neville Papers at Beinecke Rare Book and Manuscript Library (reprinted by kind permission of the Estate of Richard Neville); Felix Dennis Archive courtesy of James Birch and Barry Miles; Andrew Sclanders/BeatBooks.com; and the private collections of Marsha Rowe, Richard Adams, James Birch and Geoffrey Robertson. Material by Martin Sharp appears with the kind permission of the Estate of Martin Sharp.

The **Reading Room** is organised by Gaia Giacomelli, Chinmayi Swami, Max Jones, Maria Kobzareva, Paul Davey, and Ryan Blakeley, students from the Chelsea College of Arts MA Curating and Collections course. This space incorporates material from the British underground press, OZ Sydney and *Spare Rib*, with original and archival material from the private collection of Marsha Rowe, co-founder of the magazine, Spare Rib, the collection of Andrew Sclanders / BeatBooks.com, and the Felix Dennis Archive courtesy of James Birch and Barry Miles.

The publication includes original contributions from Jim Anderson, Philippe Mora and Marsha Rowe.

Special thanks to Richard Adams, Jim Anderson, Stephen Bartley (Archivist at the Chelsea Arts Club), Caroline Coon, James Birch, Felicity Fenner (UNSW Galleries), Louise Ferrier, Mia Gubbay, Jonathon Green, Anne Marie Menta, Barry Miles, Philippe Mora, Tina Mickelthwaite, Geoffrey Robertson, Marsha Rowe, Andrew Sclanders / BeatBooks.com, Ben Whitaker, the Estate of Richard Neville, the Estate of Martin Sharp, the Felix Dennis Archive courtesy of James Birch and Barry Miles, and Beinecke Rare Book and Manuscript Library, Yale University, University of Wollongong Historical & Cultural Collections (<http://ro.uow.edu.au/ozlondon/>).

OZ no. 5 appears in the exhibition with the help of the **MA Conservation department at Camberwell College of Arts, Jocelyn Cuming, Eleni Katsiani, Craig Horsfall.**

This exhibition would not have been possible without the kind support and inspiration of Clytie Jessop (nee Lloyd-Jones) who sadly passed away in April this year.

ual: chelsea
college of arts

CHELSEA
ARTS CLUB
TRUST

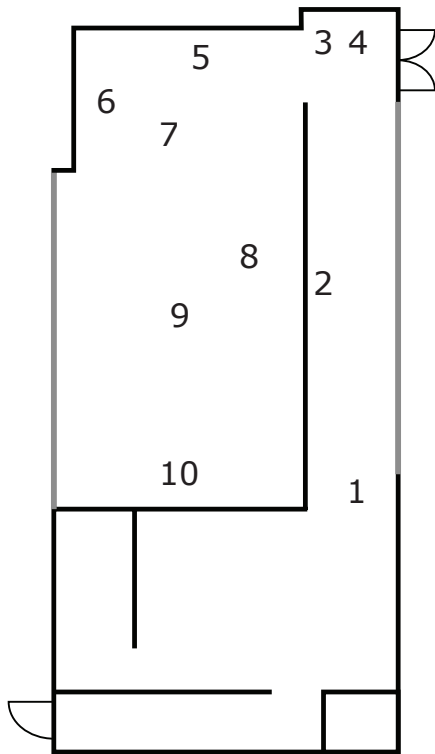

RAMP and MAIN SPACE ITEM LIST

1. Martin Sharp and Robert Whitaker, 'Plant a Flower Child', poster for OZ 5, 1967

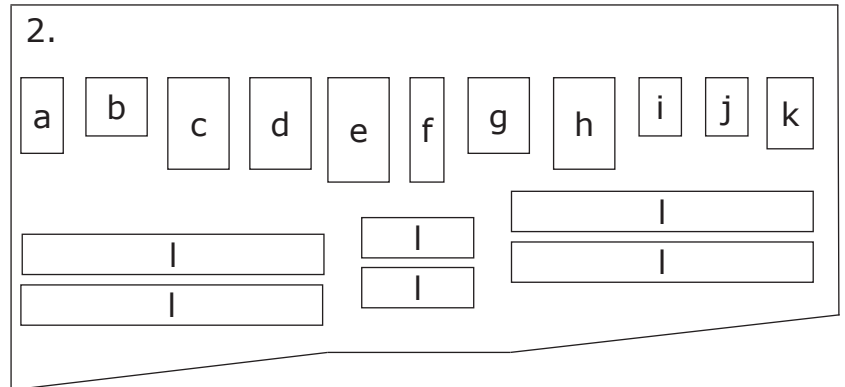

2.

- a. Martin Sharp, 'OZ London is a New Magazine', 1967
 - b. Martin Sharp, 'OZ - Join the Lost Generation', Big O Posters, London, 1968.
 - c. Martin Sharp, 'Toad of Whitehall', 1967
 - d. Lawson/Clive-Smith, 'Geuvara is dead... Long Live Geuvara', 1968
 - e. Eric Stodge and Barney bubbles, Summer OZ Supplement 'Existence is unhappiness', 1968
 - f. Nigel Weymouth and Michael English, 'Catherin and the Wheel of Fire', cover for OZ 13, 1968
 - g. OZ 25 insert, 'Outcry! From occupied Berkeley', 1969
 - h. Robert Crumb, 'Honey Bunch Kaminski', poster for OZ 24, 1969
 - i. Mike McInnerney, 'Jimi Hendrix', poster for OZ 30, 1970
 - j. Janice Joplin memorial poster for OZ 36, 1971
 - k. Poster advertising OZ 48, 1973
 - l. OZ London 1-48
- 1, 2, 3, 4, 11, 12, 13: private collection Richard Adams
 5, 6, 7, 28, 30, 33: Felix Dennis Archive courtesy of James Birch and Barry Miles

3. Martin Sharp, 'Blowing in the Mind - Mister Tambourine Man', Big O Posters, London, 1967. On loan from Andrew Sclanders / BeatBooks.com

4. Martin Sharp, 'OZ Number Four', promotional poster for OZ magazine No.4, June 1967. On loan from Andrew Sclanders / BeatBooks.com

5. OZ Sydney

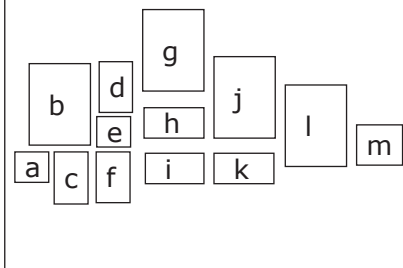

5.

- a. OZ Sydney fundraising invitation, 1966, designed by Martin Sharp. On loan from Marsha Rowe.
- b. 'OZ MEN JAILED FOR OBSCENITY', Telegraph, newspaper billboard. c. Sydney OZ 19 (1965), facsimile*
- d. Sydney OZ 6 (1964). On loan from Marsha Rowe
- e. Contact sheet of photographs of Sydney OZ editors after winning appeal, 1964. Facsimile © Mike Molloy*
- f. Offer of employment from Richard Neville to Marsha Rowe, 2 November, 1964. On loan from Marsha Rowe
- g. '3 Men in Degrading Scene', Satirical Monthly, newspaper billboard. On loan from Marsha Rowe
- h. Sydney OZ 39 (1968), OZ 23 (1965)
- i. Sydney OZ 11 (1964), OZ 17 (1965)
- j. 'The Nude Proby', photographer unknown, advertising poster for Sydney OZ 22, 1965. On loan from Marsha Rowe
- k. Sydney OZ 22 (1965) and OZ 27 (1966)
- l. Martin Sharp, 'God bless dear daddy who is fighting the Viet Cong and send him OZ', 1966. On loan from Marsha Rowe
- m. Martin Sharp, sketch for Sydney OZ 19 May 1965. On loan from Marsha Rowe.

*5b and e Reprinted by kind permission of the Estate of Richard Neville, from the Richard Neville Papers, General Collection, Beinecke Rare Book and Manuscript Library, Yale University.

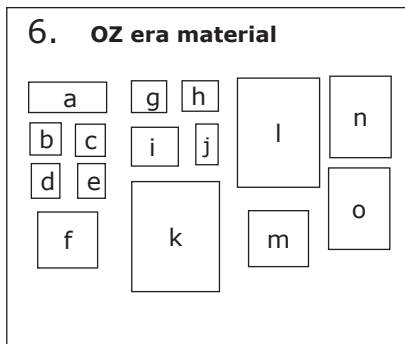

OZ related material

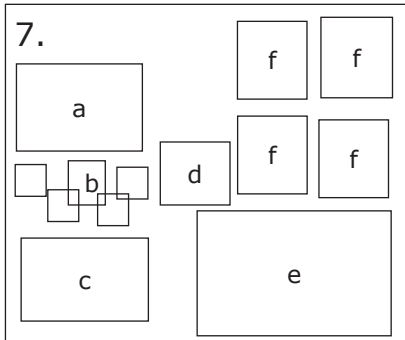

- 6.**
- Ginger Baker's Airforce, cover art by Martin Sharp, 1970
 - 'We've got nothing to hide', OZ London advertising rates card
 - The Doors, Strange Days, 1967
 - Recipe for hash cookies on OZ letterhead. On loan from Marsha Rowe
 - Letter from Richard Neville to Martin Sharp on OZ stationary, 1970. Reprinted by kind permission of the Estate of Richard Neville, from the Richard Neville Papers, General Collection, Beinecke Rare Book and Manuscript Library, Yale University.
 - 'Darling, Do You Love Me?' (1968), directed and written by Martin Sharp, photography by Robert Whitaker. Film shown with the kind permission of the Estate of Martin Sharp and the Estate of Robert Whitaker.
 - Cream, Disraeli Gears, cover art by Martin Sharp, 1967
 - Cream, Wheels of Fire, cover art by Martin Sharp, 1967
 - 'Overdrive in the Underground', Vogue Australia, February 1971 pp76-77
 - Richard Neville, 'Playpower', US edition, cover art by Richard Adams, 1971 and Richard Neville, 'Play Power', UK edition, cover art by Martin Sharp, 1970
 - Jon Goodchild, 'Headopoly', 1970. Insert from 'Play Power' UK edition.
 - Martin Sharp, 'Vincent', reprint of 1968 original, private collection James Birch.
 - 'Trouble in Molopolis', Directed by Philippe Mora, 1969. Film shown with the kind permission of Philippe Mora.
 - Martin Sharp, 'SEX!', Big O Poster, lithograph on silver foil, 1967
 - Martin Sharp, 'Legalise Cabbanis', lithograph on gold foil, 1967

- 7.**
- Letter from Jan Wenner (Rolling Stone) to Richard Neville, 29 December 1970, (facsimile)*
 - 5 badges – 3 x OZ 24, 1 x OZ 40, 1 x OZ 41. On loan from Andrew Sclanders/BeatBooks.com
 - Letter from Lillian Roxon to Louise Ferrier, undated (facsimile)*
 - Edwin Belchamber model for OZ 36 p23. Private collection Richard Adams
 - OZ 36 pp22-23, 1971
 - OZ Publications Ink Ltd post cards including "Sorry", "At Last", "Don't Panic" and "With Compliments". On loan from Andrew Sclanders/BeatBooks

*7a & c Reprinted by kind permission of the Estate of Richard Neville, from the Richard Neville Papers, General Collection, Beinecke Rare Book and Manuscript Library, Yale University.

- 8.**
- OZ 16 with two artboards. © Estate of Martin Sharp. Reprinted by kind permission of the Estate of Richard Neville, from the Richard Neville Papers, General Collection, Beinecke Rare Book and Manuscript Library, Yale University.

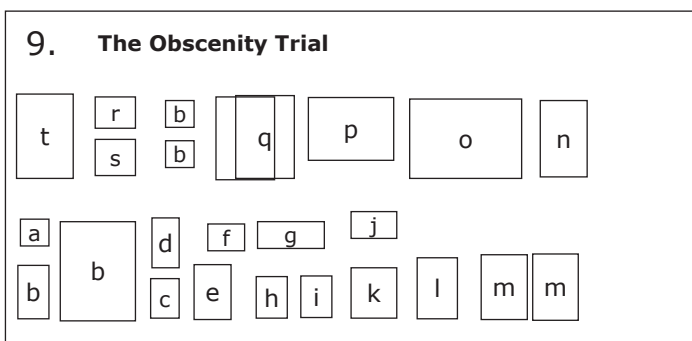

- 9.**
- Invitation to 'Obscene Courtroom Drams', 11 October 1971. On loan from Andrew Sclanders/BeatBooks.com
 - OZ Obscenity Trial Press Pack, incl. yellow and green stickers. On loan from Andrew Sclanders/BeatBooks.com
 - Street Comix sticker 'Law and Order'. On loan from Andrew Sclanders/BeatBooks.com
 - John Lennon and Yoko Ono protesting in support of the OZ defence, 1971 (facsimile). Photo © Joseph Stevens *
 - 'God Save Us', the Elastic Oz Band, written by Yoko Ono and John Lennon, produced by Phil Spector, 1971. This record was produced to raise funds for the defence for the Obscenity Trial.
 - Telegram from John Lennon and Yoko Ono to Richard Neville before the appeal, 1971 (facsimile).*
 - Caroline Coon, 'THE OZ 3, FREE!', documentation of a History Painting commissioned by Felix Dennis, June 1996. Kindly provided by Caroline Coon.
 - Tony Palmer, 'The Trials of OZ', Blond and Briggs, 1971
 - Obscene Publications Act, 1959. Private Collection Geoffrey Robertson.
 - Richard Neville's palm-card for self cross examination. Richard Neville represented himself in the Obscenity Trail, with advice from his lawyer Geoffrey Robertson. Private Collection Geoffrey Robertson.

continued over page.

9. continued...

- k. Letter from Felix Dennis to Richard Neville describing the police raid, Friday June 12 1970. Private Collection Marsha Rowe.
- l. List of witnesses from whom statements were taken for the defence, with hand written notes by Geoffrey Robertson and David Offenbach. On loan from Marsha Rowe.
- m. Two hand written notes from Geoffrey Robertson to Richard Neville while Vivian Berger was appearing for the prosecution as on the witness stand. Private Collection Geoffrey Robertson.
- n. Script for 'The Trials of Oz' by Geoffrey Robertson, BBC TV drama 1991. Private Collection Geoffrey Robertson
- o. OZ 28, 1971, pp14,15.
- p. 'Backlash' poster advertising the OZ Appeal case. Private Collection Geoffrey Robertson
- q. Time Out – July 18-24 and August 13-19. On loan from Andrew Sclanders/BeatBooks.com
- r. Telegram from Marsha Rowe to Richard Neville, Felix Dennis and Jim Anderson in prison, 1971 (facsimile)*
- s. Telegram from Martin Sharp to Richard Neville wishing him luck with the trial, 1971 (facsimile)*
- t. OZ 35, p21 with details about the fundraising auction 'Ozjet's d'Art' held at Clytie Jessop Gallery.

(* 9d, f, r, s Reprinted by kind permission of the Estate of Richard Neville, from the Richard Neville Papers, General Collection, Beinecke Rare Book and Manuscript Library, Yale University.)

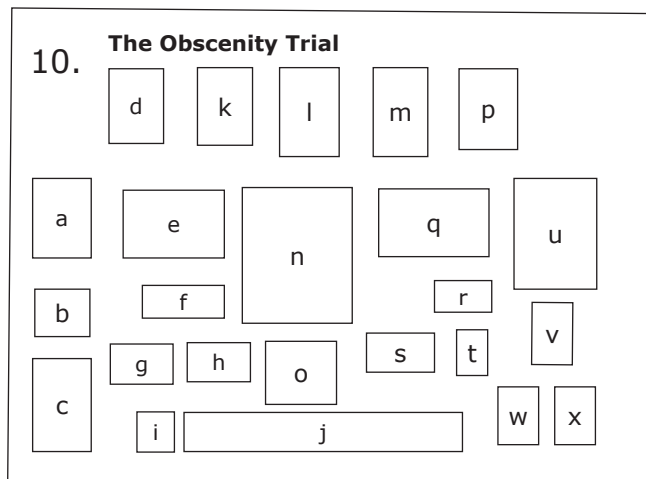

10.

- a. Oxford Playhouse poster for 'OZ', May 1972. On loan from Andrew Sclanders/BeatBooks.com
- b. 'The Trials of OZ', Playbill magazine, 1972. On loan from Geoffrey Robertson
- c. Witness statement, Germaine Greer, (4 pages, facsimile). On loan from Marsha Rowe
- d. OZ fundraising T-shirt. On loan from Richard Adams
- e. David Nutter, four photos from the Obscenity Trail Press Pack (facsimiles). On loan from Andrew Sclanders/BeatBooks.com
- f. Envelope and letter, hate mail, (4 items, facsimiles)*
- g. 'Ozjets D'Art' pamphlet and artwork list for fundraising auction at Clytie Jessop Gallery (both facsimiles)*
- h. Letter from Germaine Greer to Richard Neville, 1971 (2 pages, facsimile). Reprinted by kind permission of the Estate of Richard Neville, from the Richard Neville Papers, General Collection, Beinecke Rare Book and Manuscript Library, Yale University.
- i. Hand-written note from Geoffrey Robertson to Richard Neville regarding his closing speech for the trial, (facsimile). On loan from Geoffrey Robertson.
- j. Richard Neville's closing statement for the Obscenity Trial (7 pages, facsimiles). On loan from Geoffrey Robertson.
- k. '4-LETTER WORDS ROW: RADIO FILFTH!' Mirror, newspaper billboard, 1971 (facsimile)*
- l. 'OZ TRIAL JUDGE 'WRONG 78 TIMES' SAYS QC', Evening Standard, newspaper billboard, 1971 (facsimile)*
- m. 'OZ CASE APPEAL RESULT', Evening Standard, newspaper billboard, 1971 (facsimile)*
- n. 'Independence Day Carnival' poster. On loan from Marsha Rowe.
- o. Documentaries. 1. BBC Four interviews on censorship (Paul Ableman, Richard Neville, David Hockney, Harrison Marks). 2. BBC 'The Trials of Oz, Oz The Magazine and Dimpleby Intros'. From the Richard Neville Papers, General Collection, Beinecke Rare Book and Manuscript Library, Yale University.
- p. OZ fundraising T-shirt. On loan from Richard Adams
- q. Artboard from OZ 28 (facsimile)*
- r. Hate mail (2 pages, facsimile)*
- s. Letter from Richard Neville to his family, 4 January 1971 (facsimile)*
- t. Court summons (facsimile)*
- u. 'OZ POLICE BALL' poster (large). On loan from Andrew Sclanders/BeatBooks.com
- v. 'OZ POLICE BALL' poster (small). On loan from Andrew Sclanders/BeatBooks.com
- w. Witness statement, David Hockney, (facsimile). On loan from Marsha Rowe
- x. Jury lists, (2 pages, facsimiles). On loan from Geoffrey Robertson

(*f, g, k, l, m, q, r, s, t. Reprinted by kind permission of the Estate of Richard Neville, from the Richard Neville Papers, General Collection, Beinecke Rare Book and Manuscript Library, Yale University.)

James Birch's exhibition - 'British Underground Press 1966- 1974'.
September 27 – November 4 at A22, 22 Laystall London EC1 R4PA.